

200G QSFP56 Passive Direct Attach Copper Twinax Cable



Application

- 200 Gigabit Ethernet
- Fiber Channel over Ethernet
- Data storage and communication industry
Switch / router / HBA
- Enterprise network SAN
- Data Center Network

Standards Compliance

- IEEE 802.3cd
- QSFP56 MSA
- SFF-8436
- RoHS Compliant

Features

- QSFP56 conforms to the Small Form Factor SFF-8436
- 4-Channel Full-Duplex Passive Copper Cable Transceiver
- Power Supply :+3.3V
- Maximum aggregate data rate: 200Gb/s (4 x 50Gb/s)
- High-speed Electrical Compliant to IEEE 802.3cd
- Copper link x (x=0.5m, 1m, 1.5m, 2m, 2.5m, 3m, 3.5m)
- Support data rates : 50Gb/s PAM4 (per channel)
- I2C based two-wire serial interface for EEPROM signature which can be customized
- Operating Temperature: 0~ 70。 C
- ROHS Compliant

Description

The 200G QSFP56 DAC primarily enables high-bandwidth 200G links. It supports 200G Ethernet rate and InfiniBand HDR. It provides a QSFP56-to-QSFP56 copper direct-attach solution. 200G QSFP56 DAC cables are suitable for very short links and offer a cost-effective way to establish a 200-Gigabit link between QSFP-200G ports of switches/routers within racks and across adjacent racks.

NOTE: Only Mellanox compatible 2m and below support both Ethernet and InfiniBand applications.

Product Specifications

I. Recommended Operating Environment

Parameter	Symbol	Min	Typ.	Max	Unit	Ref.
Storage Temperature		-40		+85	°C	
Operating Case Temperature	T _c	0		+70	°C	
Power Supply Voltage	V _{CC3}	3.14	3.3	3.47	V	
Data Rate Per Lane		1		50	Gb/s	

II. Electrical Characteristics

Item	Specification	Notes
SDD21 & SDD12	-17.16 dB Min. @13.28 GHz	From 0.01 GHz-19GHz
SDD11 & SDD22	-16.5+2*sqrt(f)dB Max. @0.05GHz~4.1GHz -10.66+14*log(f/5.5)dB Max.@4.1GHz~10GHz	From 0.01 GHz- 19GHz
SCD21-SDD21	-10 dB Max. @0.01 GHz~12.89 GHz -27+(29/22)*f dB Max. @12.89 GHz~15.7 GHz -6.3 dB Max. @15.7 GHz~19 GHz	From 0.01 GHz- 19GHz

IV. Pin Assignment

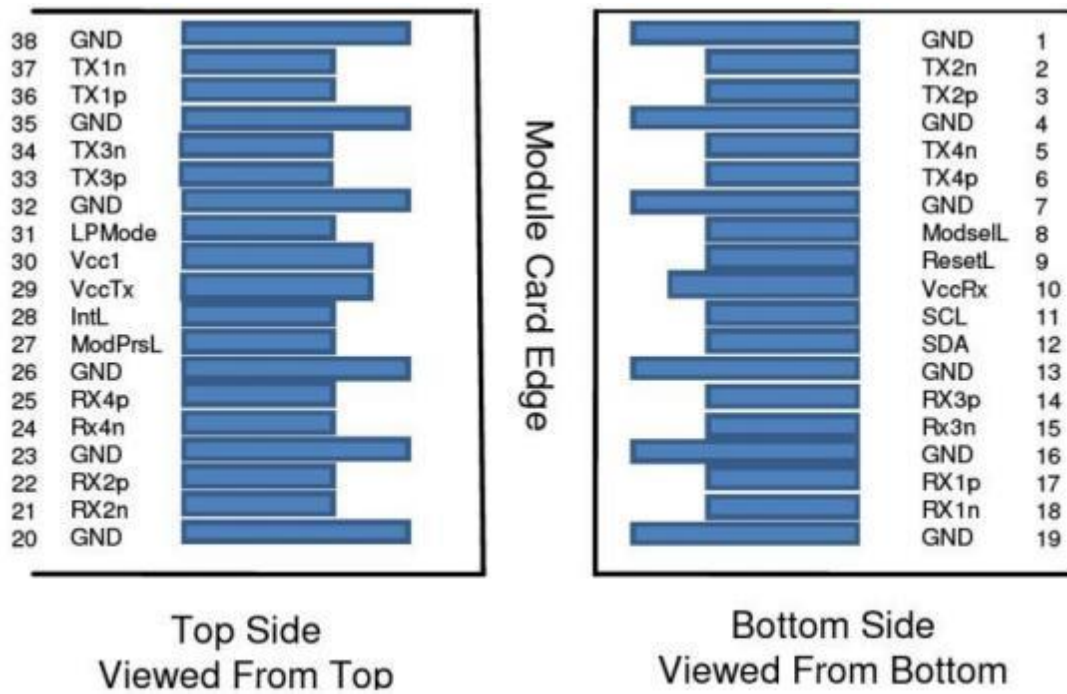

Pin	Logic	Symbol	Description	Notes
1		GND	Ground	1
2	CML-I	Tx2n	Transmitter Inverted Data	
3	CML-I	Tx2p	Transmitter Non-Inverted	
4		GND	Ground	1
5	CML-I	Tx4n	Transmitter Inverted Data	
6	CML-I	Tx4p	Transmitter Non-Inverted	
7		GND	Ground	1
8	LVTTTL-I	ModSelL	Module Select	
9	LVTTTL-I	ResetL	Module Reset	
10		VccRx	+3.3 V Power Supply	2
11	LVCNOS	SCL	2-wire serial interface	
12	LVCNOS	SDA	2-wire serial interface	
13		GND	Ground	1

14	CML-O	Rx3p	Receiver Non-Inverted	
15	CML-O	Rx3n	Receiver Inverted Data	
16		GND	Ground	1
17	CML-O	Rx1p	Receiver Non-Inverted	
18	CML-O	Rx1n	Receiver Inverted Data	
19		GND	Ground	1
20		GND	Ground	1
21	CML-O	Rx2n	Receiver Inverted Data	
22	CML-O	Rx2p	Receiver Non-Inverted	
23		GND	Ground	1
24	CML-O	Rx4n	Receiver Inverted Data	
25	CML-O	Rx4p	Receiver Non-Inverted	
26		GND	Ground	1
27	LVTTTL-O	ModPrsL	Module Present	
28	LVTTTL-O	IntL	Interrupt	
29		Vcc Tx	+3.3V Power supply	2
30		Vcc1	+3.3V Power supply	2
31	LVTTTL-I	LPMode	Low Power Mode	
32		GND	Ground	1
33	CML-I	Tx3p	Transmitter Non-Inverted	
34	CML-I	Tx3n	Transmitter Inverted Data	
35		GND	Ground	1
36	CML-I	Tx1p	Transmitter Non-Inverted	
37	CML-I	Tx1n	Transmitter Inverted Data	
38		GND	Ground	1

Notes:

1. GND is the symbol for signal and supply (power) common for the QSFP+ module. All are common within the QSFP+ module and all module voltages are referenced to this potential unless otherwise noted. Connect these directly to the hostboard signal-common ground plane.
2. Vcc Rx, Vcc1 and Vcc Tx are the receiver and transmitter power supplies and shall be applied concurrently. Requirements defined for the host side of the Host Edge Card Connector are listed in Table 6. Recommended host board power supply filtering is shown in Figure 4. Vcc Rx Vcc1 and Vcc Tx may be internally connected within the QSFP+ Module module in any combination. The connector pins are each rated for a maximum current of 500 mA.

V. Channel insertion loss budget

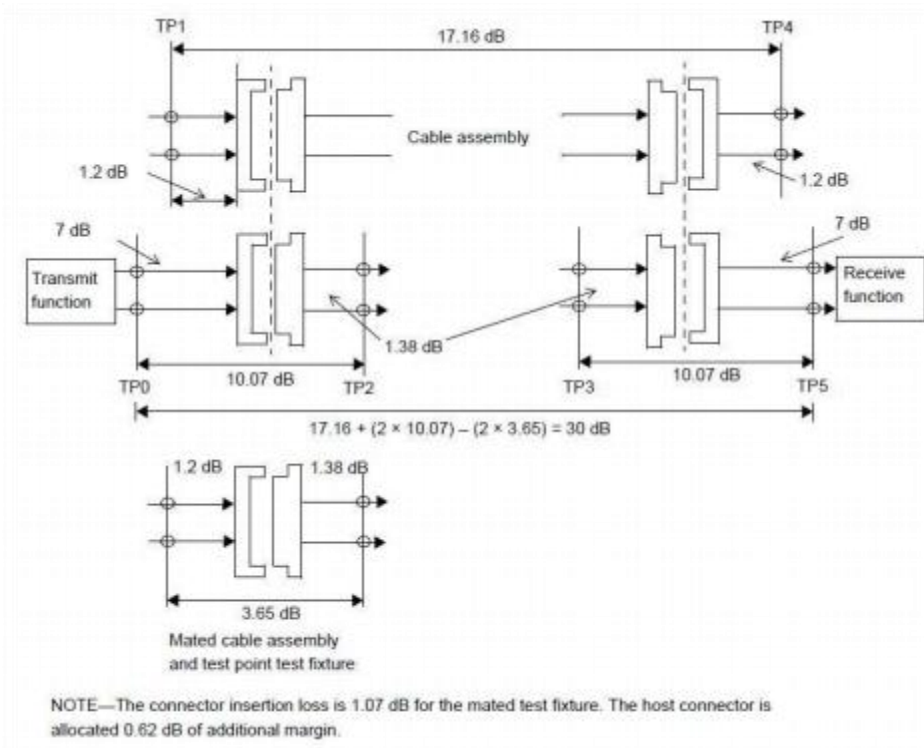

35dB Channel insertion loss budget at 13.28 GHz

VI. Assembly Bend Radius & Install Radius

Cable Gauge	Diameter "OD"	Min. Bend Radius "R"	Min. Bend Space "L"
30AWG	7.8mm	39mm	80mm
26AWG	8.9mm	44.5mm	89mm

VII. Diagram Mechanical Drawing

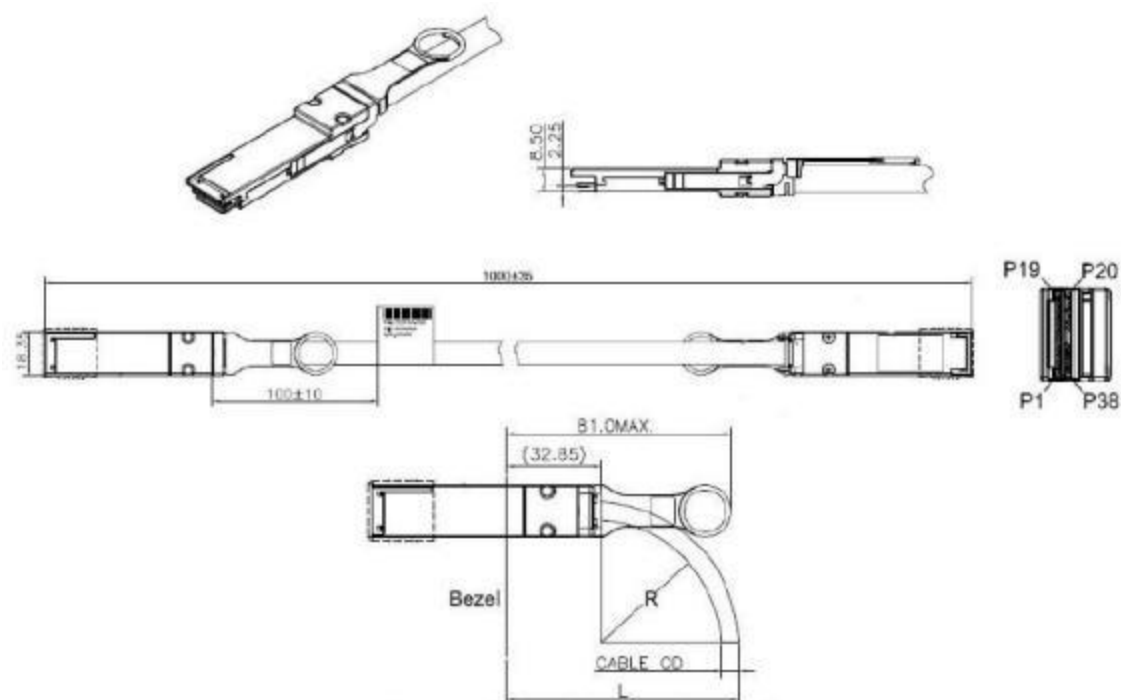

Test Center

FS.COM transceivers are tested to ensure connectivity and compatibility in our test center before shipped out. FS.COM test center is supported by a variety of mainstream original brand switches and groups of professional staff, helping our customers make the most efficient use of our products in their systems, network designs and deployments.

The original switches could be found nowhere but at FS.COM test center, eg: Juniper MX960 & EX 4300 series, Cisco Nexus 9396PX & Cisco ASR 9000 Series, HP 5900 Series & HP 5406R ZL2 V3(J9996A), Arista 7050S-64, Brocade ICX7750-26Q & ICX6610-48, Avaya VSP 7000 MDA 2, etc.



Cisco ASR 9000 Series(A9K-MPA-1X40GE)



ARISTA 7050S-64(DCS-7050S-64)



Juniper MX960



Brocade ICX 7750-26Q



Extreme Networks X670V VIM-40G4X



Mellanox M3601Q



Dell N4032F



HP 5406R ZL2 V3(J9996A)



AVAYA 7024XLS(7002QQ-MDA)

Test Assured Program

FS.COM truly understands the value of compatibility and interoperability to each optics. Every module FS.COM provides must run through programming and an extensive series of platform diagnostic tests to prove its performance and compatibility. In our test center, we care of every detail from staff to facilities—professionally trained staff, advanced test facilities and comprehensive original-brand switches, to ensure our customers to receive the optics with superior quality.



Our smart data system allows effective product management and quality control according to the unique serial number, properly tracing the order, shipment and every part.



With a comprehensive line of original-brand switches, we can recreate an environment and test each optics in practical application to ensure quality and distance.



Our in-house coding facility programs all of our parts to standard OEM specs for compatibility on all major vendors and systems such as Cisco, Juniper, Brocade, HP, Dell, Arista and so on.



The last test assured step to ensure our products to be shipped with perfect package.

Ordering Information

Part Number	Data Rate	Length	Wire Gauge	Connector Type	Temp. Range	Cable Jacket
QSFP-200G-PC005	200G	0.5m	30AWG	Passive Copper	0-70°C	PVC
QSFP-200G-PC01	200G	1m	30AWG	Passive Copper	0-70°C	PVC
QSFP-200G-PC015	200G	1.5m	30AWG	Passive Copper	0-70°C	PVC
QSFP-200G-PC02	200G	2m	30AWG	Passive Copper	0-70°C	PVC
QSFP-200G-PC03	200G	3m	26AWG	Passive Copper	0-70°C	PVC