

# 800GBASE-DR8 OSFP 1310nm 500m DOM Dual MPO-12/APC Transceiver, Finned Top

OSFP-DR8-800G

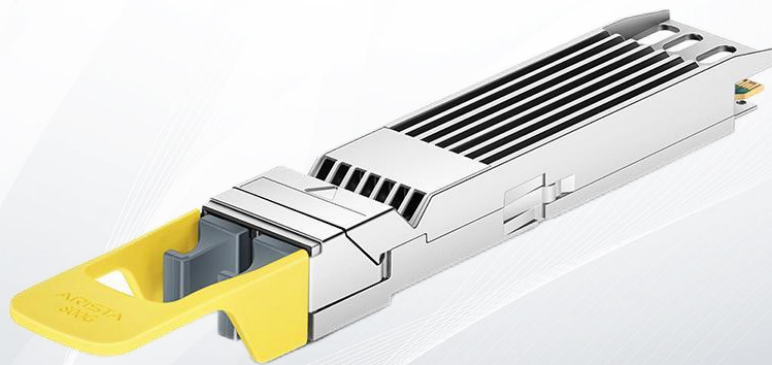

## Application

- 800G InfiniBand
- 2x 400GBASE-DR4
- Cloud Networks

## Features

- Compliant with IEEE 802.3cu-2021: - 2x400GBASE-DR4 optical interface
- Compliant with IEEE P802.3ck D2.2 - 2x400GAUI-4 C2M electrical interface
- Compliant with OSFP MSA HW Rev 4.1 Type 2 housing with Dual MPO-12 connector
- Compliant with CMIS Rev 5.0
- Maximum Power Consumption 16.5W
- Operating Temperature Range: 0°C ~ +70 °C
- Two Wire Serial Interface with Digital Diagnostic Monitoring
- Class 1 Laser Safety

## Description

The FS for Mellanox MMS4X00-NM Compatible OSFP Optical Transceiver Module is designed for 800GBASE throughput up to 500m over single-mode fiber (SMF) with dual MTP/MPO-12 connectors. The OSFP-DR8-800G module can convert 8-channel 106.25Gb/s electrical data to 8-channel 106.25Gb/s optical signals. Similarly, it optically converts 8-channel 106.25Gb/s optical signals to 8-channel electrical data output on the receiver side. It has been designed to withstand the maximum range of external operating conditions including temperature, humidity and EMI. The OSFP-DR8-800G Optical Transceiver is a high performance, cost effective module for optical data communication applications supporting 800G InfiniBand.

## Product Specifications

### I. Absolute Maximum Ratings

Parameter	Symbol	Min	Max	Unit	Notes
<b>Storage Temperature Range</b>	TS	-40	85	°C	
<b>Supply Voltage</b>	V <sub>CC</sub>	-0.5	3.6	V	
<b>Relative Humidity (non-condensing)</b>	RH	5	95	%	
<b>Data Input Voltage Differential</b>	IV <sub>DIP</sub> -V <sub>DIN</sub> I		1	V	
<b>Control Input Voltage</b>	VI	-0.3	V <sub>CC</sub> +0.5	V	
<b>Control Output Current</b>	I <sub>O</sub>	-20	20	mA	

### II. Recommended Operating Conditions

Parameter	Symbol	Min	Typ.	Max	Unit	Notes
<b>Operating Case Temperature</b>	T <sub>OPR</sub>	0		70	°C	1
<b>Power Supply Voltage</b>	V <sub>CC</sub>	3.135	3.3	3.465	V	
<b>Instantaneous peak current at hot plug</b>	I <sub>CC_IP</sub>				mA	
<b>Sustained peak current at hot plug</b>	I <sub>CC_SP</sub>				mA	
<b>Maximum Power Dissipation</b>	P <sub>D</sub>			16.5	W	

<b>Maximum Power Dissipation, Low Power Mode</b>	$P_{DLP}$				W	
<b>Signalling Speed per Lane</b>	DRL		53.125		GBd	
<b>Control Input Voltage High</b>	$V_{IH}$	$V_{CC} * 0.7$		$V_{CC} + 0.3$	V	
<b>Control Input Voltage Low</b>	$V_{IL}$	-0.3		$V_{CC} * 0.3$	V	
<b>Two Wire Serial Interface Clock Rate</b>				400	kHz	
<b>Power Supply Noise 1 kHz - 1 MHz (p-p)</b>				66	mVpp	
<b>Operating Distance</b>		2		500	m	

### III. Optical Characteristics

Parameter	Symbol	Min	Typ.	Max	Unit	Notes
<b>Wavelength</b>	$\lambda_C$	1304.5	1311	1317.5	nm	

#### Transmitter (per Lane)

<b>Side Mode Suppression Ratio</b>	SMSR	30			dB	
<b>Average Launch Power, each lane</b>	$AOP_L$	-2.9		4.0	dBm	1
<b>Outer Optical Modulation Amplitude (OMA<sub>outer</sub>), each Lane</b>	$T_{OMA}$	-0.8		4.2	dBm	
<b>Launch Power in OMA<sub>outer</sub> minus TDECQ, each lane</b>	$T_{OMA-TDECQ}$	-2.2			dBm	
<b>Transmitter and Dispersion Eye Closure for PAM4 (TDECQ), each lane</b>	TDECQ			3.4	dB	
<b>Average Launch Power of OFF Transmitter, each lane</b>	$T_{OFF}$			-15	dBm	
<b>Extinction Ratio</b>	ER	3.5			dB	
<b>Transmitter transition time (max)</b>	$T_r$			17	ps	

<b>RIN21.4OMA (max)</b>	RIN			-136	dB/Hz	
<b>Optical Return Loss Tolerance</b>	ORL			21.4	dB	
<b>Transmitter Reflectance</b>	$T_R$			-26	dB	2

#### Receiver (Per lane)

<b>Wavelength L0</b>	$\lambda_{CO}$	1304.5	1311	1317.5	nm	
<b>Damage Threshold, each Lane</b>	$AOP_D$	5			dBm	
<b>Average Receive Power, each Lane</b>	$AOP_R$	-5.9		4	dBm	
<b>Receive Power (OMAouter), each Lane</b>	$OMA_R$			4.2	dBm	
<b>Receiver Reflectance</b>	RR			-26	dB	
<b>Receiver Sensitivity (OMAouter), each Lane</b>	$S_{OMA}$			Max(-3.9, SECQ - 5.3)	dBm	3
<b>Stressed Receiver Sensitivity (OMAouter), each Lane</b>	SRS			-1.9	dBm	4

#### Conditions of stressed receiver sensitivity test

<b>Stressed eye closure for PAM4 (SECQ), lane under test</b>	SECQ		3.4		dB	
<b>OMAouter of each aggressor lane</b>			4.2			

#### Notes:

- 1: Average launch power, each lane (min) is informative and not the principal indicator of signal strength
- 2: Transmitter reflectance is defined looking into the transmitter
- 3: Receiver sensitivity (OMAouter), each lane (max) is informative and is defined for a transmitter with a value of SECQ up to 3.4 dB.
- 4: Measured with conformance test signal at TP3 for the BER =  $2.4 \times 10^{-4}$

#### IV. Electrical Characteristics(compliant with IEEE P802.3ck C2M))

Parameter	Symbol	Min	Typ.	Max	Unit	Notes
<b>Transmitter (per Lane)</b>						
<b>AC common-mode output Voltage (RMS)</b>				25	mV	
<b>Differential peak-to-peak output voltage</b>				600	mV	
<b>Short mode</b>				900	mV	
<b>Long mode</b>						
<b>Eye height, differential</b>	EH	15			mV	
<b>Vertical eye closure</b>	VEC			12	dB	
<b>Common-mode to differential return loss</b>	RLDc		802.3ck 120G-1		dB	
<b>Effective return loss, ERL</b>	ERL	8.5			dB	
<b>Differential termination mismatch</b>				10	%	
<b>Transition time (20% to 80%)</b>		8.5			ps	
<b>Receiver (per Lane)</b>						
<b>Differential pk-pk input Voltage tolerance</b>		900			mV	
<b>AC common-mode RMS voltage tolerance (TP1a)</b>		25			mV	
<b>Differential to common-mode return loss</b>	RLcd		802.3ck 120G-2		dB	
<b>Effective return loss, ERL</b>	ERL	8.5			dB	
<b>Differential termination mismatch</b>				10	%	
<b>Single-ended voltage tolerance range</b>		-0.4		3.3	V	
<b>DC common-mode Voltage</b>		-0.35		2.85	V	

## V. Electrical Specification Low Speed Signal

Parameter	Symbol	Min	Max	Unit	Condition
<b>Module output SCL and SDA</b>	$V_{OL}$	0	0.4	V	
<b>Module Input SCL and SDA</b>	$V_{IL}$	-0.3	$V_{CC} * 0.3$	V	
	$V_{IH}$	$V_{CC} * 0.7$	$V_{CC} + 0.5$	V	
<b>LPMode/TxDis, ResetL and ModSelL</b>	$V_{IL}$	-0.3	0.8	V	
	$V_{IH}$	2	$V_{CC} + 0.3$	V	
<b>IntL/RxLos</b>	$V_{OL}$	0	0.4	V	
	$V_{OH}$	$V_{CC} - 0.5$	$V_{CC} + 0.3$	V	

## VI. Pin Definitions

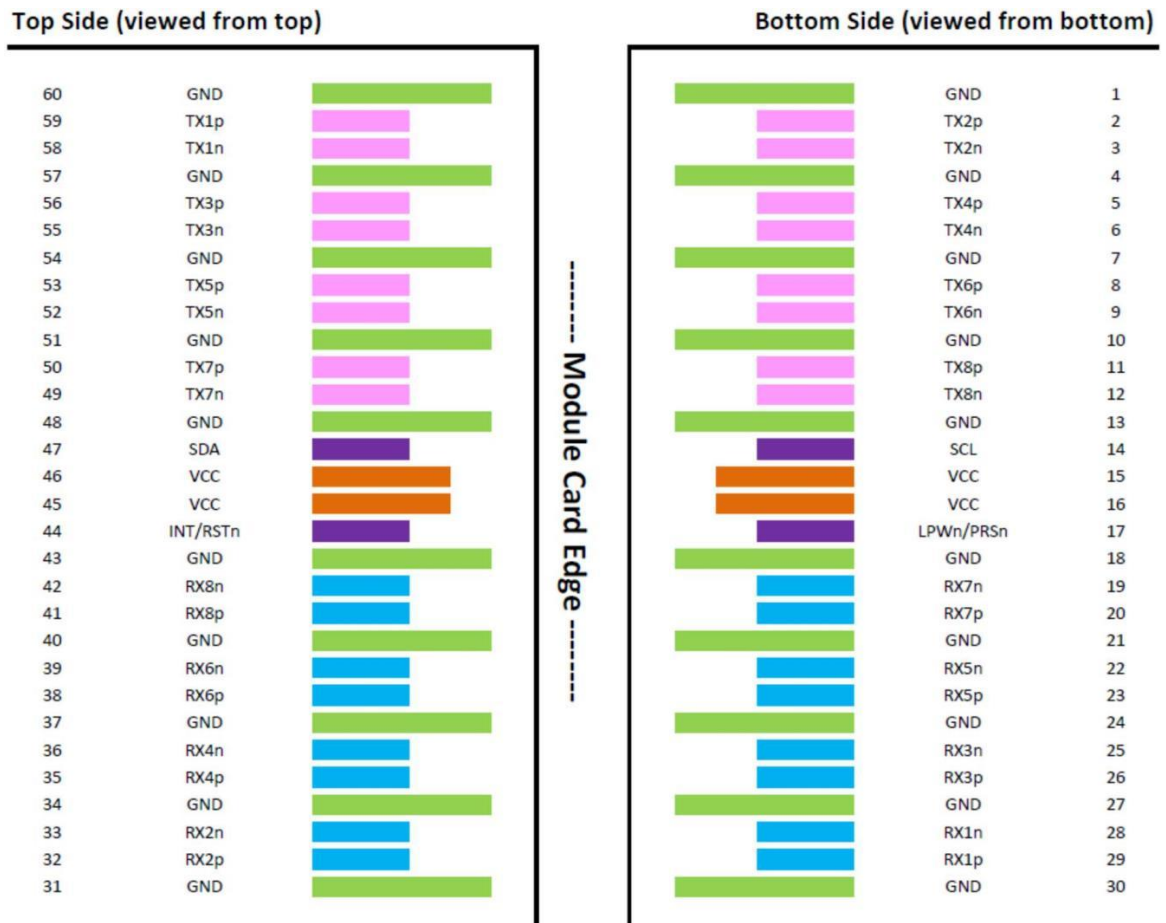

Figure 1 – Pinout definitions of OSFP module inputs/outputs

## VII. Pin Definitions

PIN	Symbol	Description	Logic	Note
1	GND	Ground		
2	TX2p	Transmitter Data Non-Inverted	CML-I	
3	TX2n	Transmitter Data Inverted	CML-I	
4	GND	Ground		
5	TX4p	Transmitter Data Non-Inverted	CML-I	
6	TX4n	Transmitter Data Inverted	CML-I	
7	GND	Ground		
8	TX6p	Transmitter Data Non-Inverted	CML-I	
9	TX6n	Transmitter Data Inverted	CML-I	
10	GND	Ground		
11	TX8p	Transmitter Data Non-Inverted	CML-I	
12	TX8n	Transmitter Data Inverted	CML-I	
13	GND	Ground		
14	SCL	2-wire Serial interface clock	LVC MOS-I/O	
15	VCC	+3.3V Power		
16	VCC	+3.3V Power		
17	LPWn/PRS <sub>n</sub>	Low-Power Mode / Module Present	Multi-Level	
18	GND	Ground		
19	RX7n	Receiver Data Inverted	CML-O	
20	RX7p	Receiver Data Non-Inverted	CML-O	
21	GND	Ground		

22	RX5n	Receiver Data Inverted	CML-O	
23	RX5p	Receiver Data Non-Inverted	CML-O	
24	GND	Ground		
25	RX3n	Receiver Data Inverted	CML-O	
26	RX3p	Receiver Data Non-Inverted	CML-O	
27	GND	Ground		
28	RX1n	Receiver Data Inverted	CML-O	
29	RX1p	Receiver Data Non-Inverted	CML-O	
30	GND	Ground		
31	GND	Ground		
32	RX2p	Receiver Data Non-Inverted	CML-O	
33	RX2n	Receiver Data Inverted	CML-O	
34	GND	Ground		
35	RX4p	Receiver Data Non-Inverted	CML-O	
36	RX4n	Receiver Data Inverted	CML-O	
37	GND	Ground		
38	RX6p	Receiver Data Non-Inverted	CML-O	
39	RX6n	Receiver Data Inverted	CML-O	
40	GND	Ground		
41	RX8p	Receiver Data Non-Inverted	CML-O	
42	RX8n	Receiver Data Inverted	CML-O	
43	GND	Ground		
44	INT/RSTn	Module Interrupt / Module Reset	Multi- Level	
45	VCC	+3.3V Power		
46	VCC	+3.3V Power		
47	SDA	2-wire Serial interface data	LVCM OS-I/O	
48	GND	Ground		
49	TX7n	Transmitter Data Inverted	CML-I	
50	TX7p	Transmitter Data Non-Inverted	CML-I	
51	GND	Ground		
52	TX5n	Transmitter Data Inverted	CML-I	
53	TX5p	Transmitter Data Non-Inverted	CML-I	
54	GND	Ground		

55	TX3n	Transmitter Data Inverted	CML-I
56	TX3p	Transmitter Data Non-Inverted	CML-I
57	GND	Ground	
58	TX1n	Transmitter Data Inverted	CML-I
59	TX1p	Transmitter Data Non-Inverted	CML-I
60	GND	Ground	

### VIII. Recommended OSFP Host Board Schematic

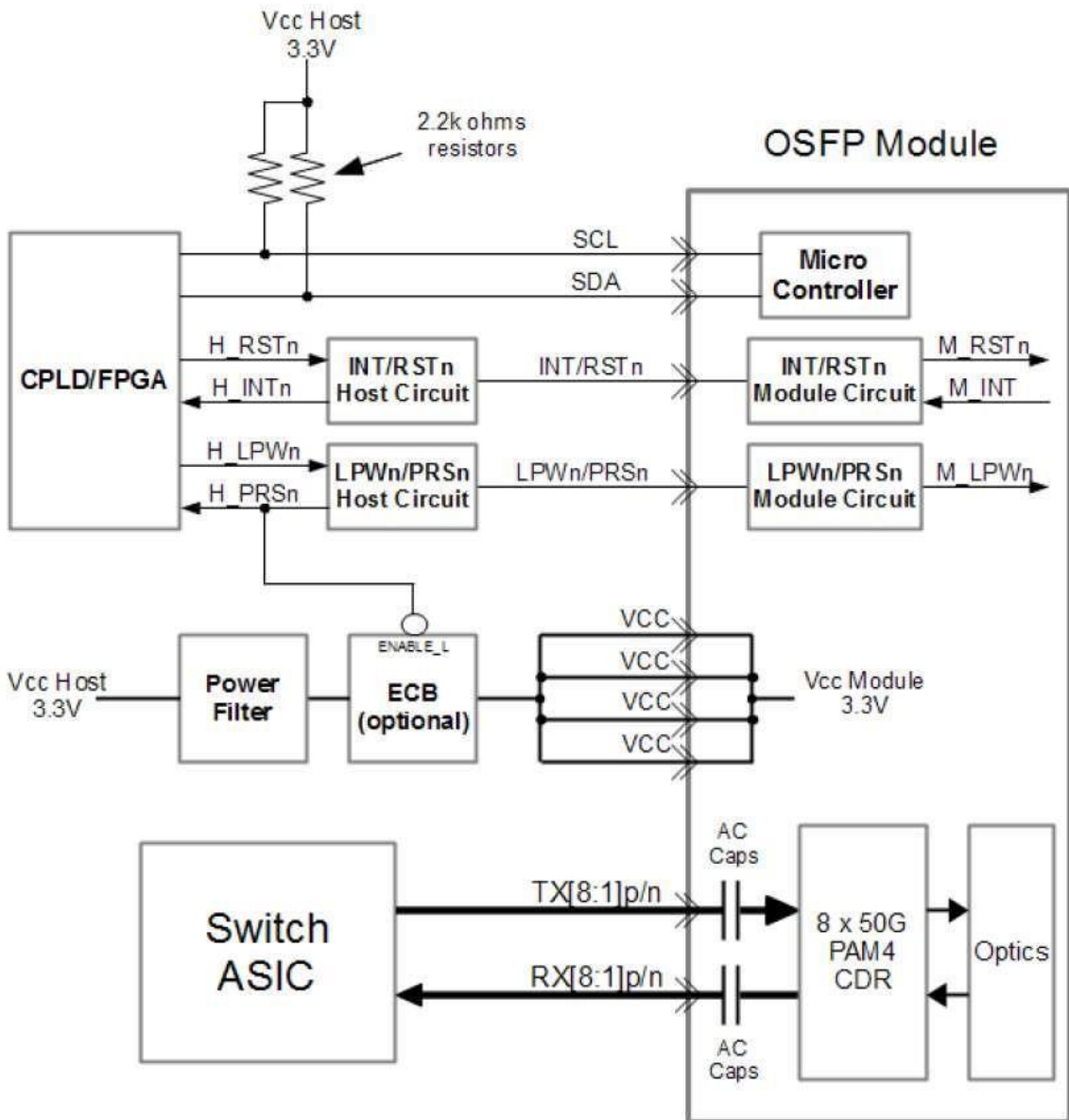
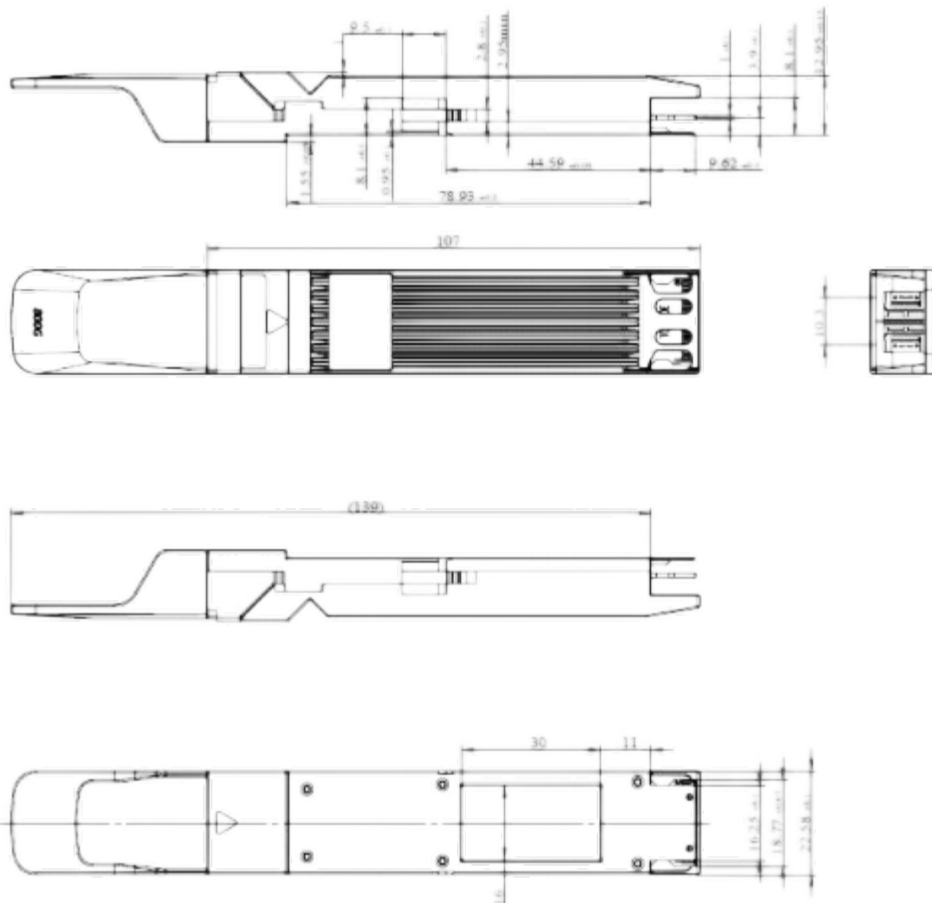

Figure 2. Recommended OSFP Host Board Schematic

### IX. Digital Diagnostics

Parameter	Range	Accuracy	Unit	Calibration
Temperature	0 to 70	±3	°C	Internal
Voltage	0 to V <sub>CC</sub>	0.1	V	Internal
Tx Bias Current (Each Lane)	0 to 100	10%	mA	Internal
Tx Output Power (Each Lane)	-2.8 to +5.3	±3	dB	Internal
Rx Receive Power (Each Lane)	-9.1 to +5.3	±3	dB	Internal

### X. Mechanical Diagram



## Test Center

### I. Compatibility Testing

Each fiber optical transceiver has been tested in host device on site in FS Assured Program to ensure full compatibility with over 200 vendors.



Cisco Catalyst C9500-24Y4C



Cisco MS425-16



Brocade VDX 6940-144S



Dell EMC Networking Z9100-ON



Force<sup>10</sup> S60-44T



HUAWEI S6720-30L-HI-24S

Above is part of our test bed network equipment. For more information, please click the Test Bed PDF. It will be updated in real time as we expand our portfolio.

## II. Performance Testing

Each fiber optical transceiver has been fully tested in FS Assured Program equipped with world's most advanced analytical equipment to ensure that our transceivers work perfectly on your device.

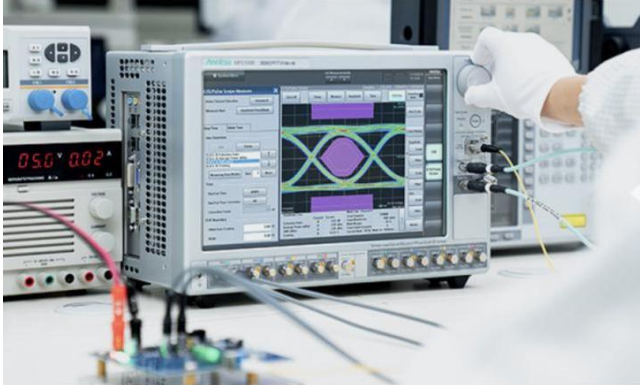

### 1. TX/RX Signal Quality Testing

Equipped with the all-in-one tester integrated 4ch BERT & sampling oscilloscope, and variable optical attenuator to ensure the input and output signal quality.

- Eye Pattern Measurements: Jitter, Mask Margin, etc
- Average Output Power
- OMA
- Extinction Ratio
- Receiver Sensitivity
- BER Curve

### 2. Reliability and Stability Testing

Subject the transceivers to dramatic changes in temperature on the thermal shock chamber to ensure reliability and stability of the transceivers.

- Commercial: 0 °C to 70 °C
- Extended: -5 °C to 85 °C
- Industrial: -40 °C to 85 °C



### 3. Transfer Rate and Protocol Testing

Test the actual transfer data rate and the transmission ability under different protocols with Network Master Pro.

- Ethernet
- Fibre Channel
- SDH/SONET
- CPRI



### 4. Optical Spectrum Evaluation

Evaluate various important parameters with the Optical Spectrum Analyzer to meet the industry standards.

- Center Wavelength, Level
- OSNR
- SMSR
- Spectrum Width

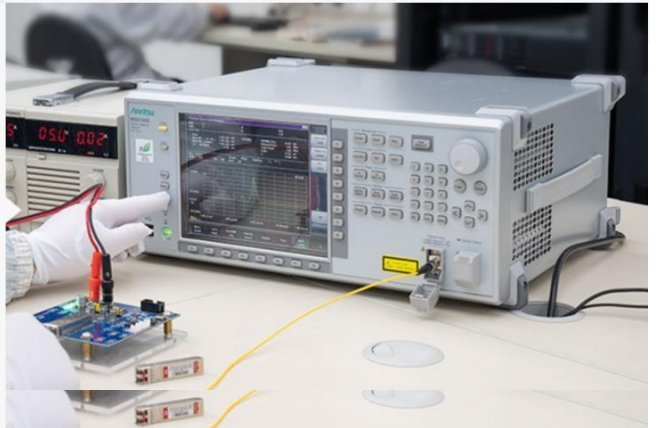

## Ordering Information

Part Number	Description
OSFP-SR8-800G	OSFP 800GBASE-SR8 1310nm 50m Transceiver
OSFP-DR8-800G	OSFP 800GBASE-DR8 1310nm 500m Transceiver
OSFP-2FR4-800G	OSFP 800GBASE-2FR4 1310nm 2km Transceiver