

Industrial GPON SFP ONU Stick with MAC

GPON-SFP-ONT-MAC-I



Application

- GPON ONT
- FTTx and Wireless Backhaul
- MDU/MTU Access

Features

- SFP MSA compliant
- Compliant to FSAN G.984.2 Specifications
- digital diagnostics SFF-8472 Compliant
- Subscriber location identifier (SLID)
- PON Link status notification
- Dying Gasp notification support
- Up to 20km transmission
- 28 dB link budget;
- SCAPC Simplex connector
- Class B+
- Operating case temperature: -40 °C to +85 °C

Description

FS GPON-SFP-ONT-MAC-I GPON Stick ONU with Small Form-factor Pluggable (SFP) packaging, which integrates a bi-directional optical transceiver function and GPON MAC function. By being plugged into the customer premise equipment (CPE) with standard SFP port directly, provides an asymmetric 1.244Gbps upstream /2.488 Gbps downstream GPON uplink to the CPE without requiring separate power supply, supports a sophisticated ONT management system, including alarms, provisioning, DHCP and IGMP functions for a stand-alone IPTV solution at the ONT.

The GPON-SFP-ONT-MAC-I fits seamlessly into existing communications equipment, providing service providers with a smooth upgrade to GPON, vastly decreases the installation costs of deploying fiber access in MDUs.

Block Diagram

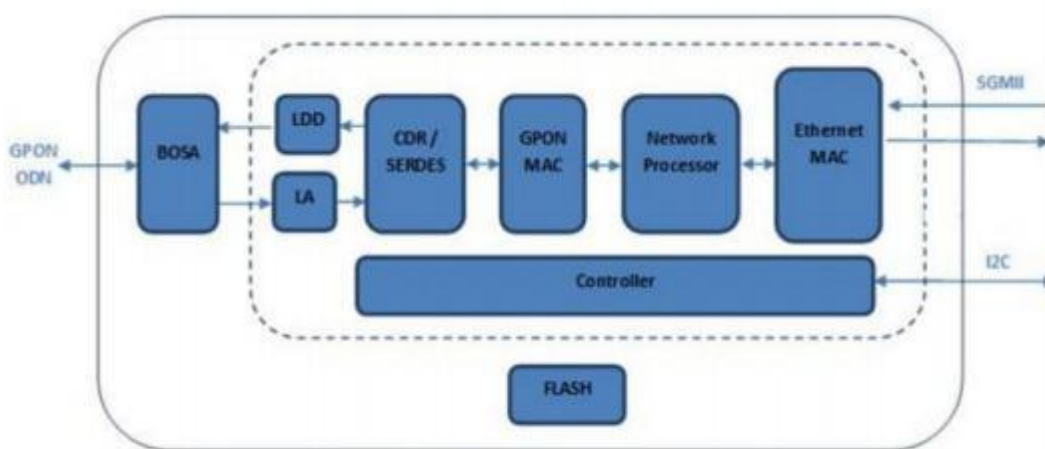

Figure 1, Block Diagram

Regulatory Compliance

Feature	Standard	Performance
Electrostatic Discharge (ESD) to the Electrical Pins	MIL-STD-883E Method 3015.7	Class 1 (>500V for data pins, >2000V for other pins)
Electrostatic Discharge (ESD) to the Duplex LC Receptacle IEC 61000-4-2	IEC 61000-4-2	Compatible with standards
Electromagnetic Interference (EMI)	FCC Part 15 Class B EN55022 Class B (CISPR 22B)	Compatible with standards
Immunity	IEC 61000-4-3	Compatible with standards
Laser Eye Safety	FDA 21CFR 1040.10 and 1040.11 EN60950, EN (IEC) 60825-1,2	Compatible with Class I laser product
RoHS	2011/65/EC	Compliant with standards

Product Specifications

Absolute Maximum Ratings

It has to be noted that the operation in of any individual absolute maximum ratings might cause permanent damage to this module.

Parameter	Symbol	Min	Typ.	Max	Unit	Ref.
Operating Voltage	Vcc	3.14	3.3	3.6	V	
Storage Temperature	Ts	-40		85	°C	
Operating Relative Humidity	RH	15		85	%	1

Notes:

1. Non-condensing

Recommended Operating Environment

Electrical and optical characteristics below are defined under this operating environment, unless otherwise specified.

Parameter	Symbol	Min	Typ.	Max	Unit	Ref.
Operating Case Temperature	Top	-40		85	°C	
Total Tx and Rx Supply Current	ICC		600		mA	
Power Dissipation	PD		2		W	
Bit Rate(Tx)	BR		1244.16			
Bit Rate(Rx)	BR		2488.32			
Transmission Distance	TD			20	km	
Module Initialize time	T_Initial			70	S	1
Two-wire serial interface Clock rate	f_serial_clock			80	Khz	

Notes:

1. Suggest do not access I2C until module initialization is completed

Electrical Characteristics

Parameter	Symbol	Min	Typ.	Max	Unit	Ref.
Transmitter						
Differential Data Input Voltage	VIN,P-P	100		1000	mVpp	1
Input Differential Impedance	ZIN		100		Ω	2
Receiver						
Differential Output Voltage		370		1000	mV	3
Signal Detect Output HIGH Voltage	VSD_High	2.4			V	4
Signal Detect Output LOW Voltage	VSD_Low	0		0.8	V	5
Data Output Rise and Fall Time	TR/TF		160		ps	

Notes:

1. TXD+/- . AC-coupled.
2. TXD+/- .
3. CML output, AC coupled(0.1 nF)
4. LVTTTL with internal 1kΩ pull up resistor. Asserts HIGH when input data amplitude is above threshold.
5. LVTTTL. De-asserts LOW when input data amplitude is below threshold.

Optical Characteristics

Parameter	Symbol	Min	Typ.	Max	Unit	Ref.
Transmitter						
Center Wavelength Range	λ_C	1290	1310	1330	nm	
Average Output Power	P _{OUT}	0.5		5	dBm	
Average Output Power (Laser Off)	P _{OUT-OFF}			-40	dBm	
Side Mode Suppression Ratio	SMSR	30			dB	
Spectral Width (-20dB)	λ_{20}			1	nm	
Extinction Ratio	ER	10			dB	1
Optical Rise and Fall Time(20%-80%)	TR/TF			250	ps	
Jitter Generation	JG			0.2	UI	2
Transmitter Output Eye	Compliant with G.984.2 Figure 3					
Receiver						
Center Wavelength Range	λ_C	1480	1490	1500	nm	
Overload		-8			dBm	
Sensitivity(BOL Room Temp)	Sen	-28			dBm	3
Signal Detect Assertion Level	SDA			-29	dBm	
Signal Detect De-Assertion Level	SDD	-45			dBm	
Hysteresis	PSDA-SDD	0.5		6	dB	
1310nm Tx to 1490nm Rx Crosstalk				-47	dB	
1555nm Rx to 1490nm Isolation		30			dB	

(1550-1560nm) Ext to 1490 Rx Isolation		34			dB	
Back Reflection @ 1310nm				-12	dB	
Back Reflection @ 1490nm				-27	dB	
Rx Reflectance				-20	dB	
1530nm to 1490nm Rx Isolation		7			dB	
1539nm to 1490nm Rx Isolation		22			dB	
1625nm to 1490nm Rx Isolation		22			dB	
1310nm Tx to 1490nm Rx Crosstalk		-	-	-47	dB	
1555nm Rx to 1490nm Isolation		30	-	-	dB	

Notes:

1. 1.Measured by Ethernet package with random payload.
2. 4kHz to 10MHz
3. Measured with Ethernet package with random payload and ER=8.2dB, BER = 10⁻¹⁰.

Pin Definitions

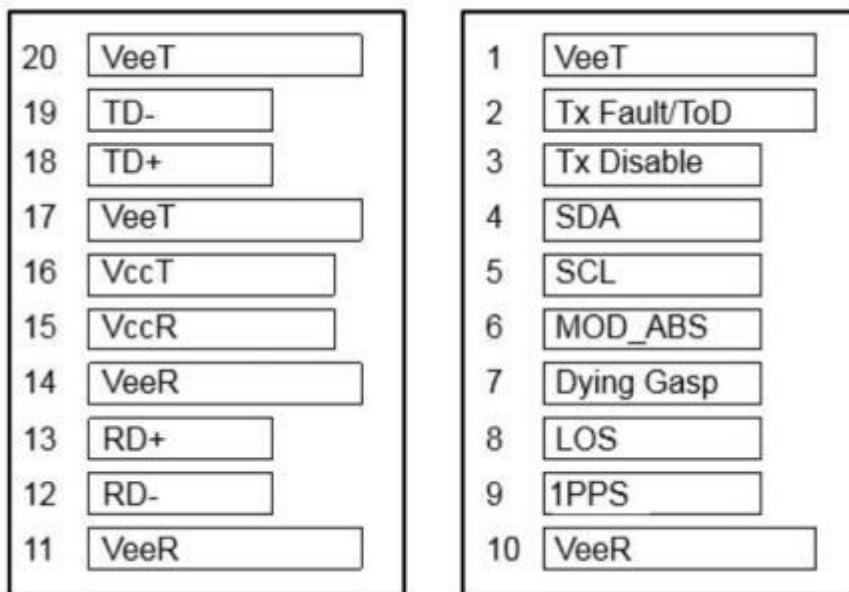

Pin	Symbol	Logic	Description	Notes
1	VeeT	NA	Module Transmitter Ground	
2	Tx Fault/ToD	LVTTTL-O	Tx Fault/Time of Day	1
3	TX_DISABLE	LVTTTL-I	Transmitter Shut-off	6
4	SDA	LVTTTL-I/O	2-Wire Serial Interface Data Line (MOD-DEF2)	2,7
5	SCL	LVTTTL-I	2-Wire Serial Interface Clock (MOD-DEF1)	2,7
6	MOD_ABS	NA	Module Absent, connected to VeeT or VeeR in the module	
7	DYING GASP	Analog Input	Dying Gasp message indicator, active low this pin has been directly connected to MAC IC in the module	3,4,5,7
8	LOS	LVTTTL-O	Loss of Signal	
9	1PPS	LVTTTL-O	1 Pulse per second	
10	VeeR	NA	Module Receiver Ground	
11	VeeR	NA	Module Receiver Ground	
12	RXD-	CML-O	Receiver Inverted Data Output	
13	RXD+	CML-O	Receiver Non-Inverted Data Output	

14	VeeR	NA	Module Receiver Ground
15	VCCR	NA	Module Receiver 3.3V Supply
16	VCCT	NA	Module Transmitter 3.3V Supply
17	VeeT	NA	Module Transmitter Ground
18	TXD+	CML-I	Transmitter Non-Inverted Data Input, CML, 100ohm differential impedance
19	TXD-	CML-I	Transmitter Inverted Data Input, CML, 100ohm differential impedance
20	VeeT	NA	Module Transmitter Ground

Notes:

1. Default Factory Mode is Tx Fault. For Small Cell type of applications, during Activation/ provisioning, it will be software configured to ToD.
2. This PIN is an open collector/drain output pin and shall be pulled up with 4.7K-10K ohms to a Host_Vcc on the host board.
3. PIN7 can support Dying Gasp function. Dying Gasp function is managed by software. If software disable the dying gasp function, ignore the PIN7 input voltage.
If software enable the function, PIN7 input voltage below Dying Gasp Assert Voltage threshold, the module will report dying gasp PLOAM to OLT.
4. Dying Gasp Voltage threshold 1.5V (typical), once software enable Dying gasp, meanwhile the pin7 input is below this threshold, it will trigger dying gasp function, transceiver will reset.
5. Host device shall maintain power to ONU module for at least 10ms during power supply drop.
6. ONU re-online process includes downlink & uplink synchronization, authentication and configuration release, etc., it normally takes >= 5 seconds
7. Transceiver full power on need 80s. Any I2C visiting.etc need to operate after this power on period.

Diagram Mechanical Drawing

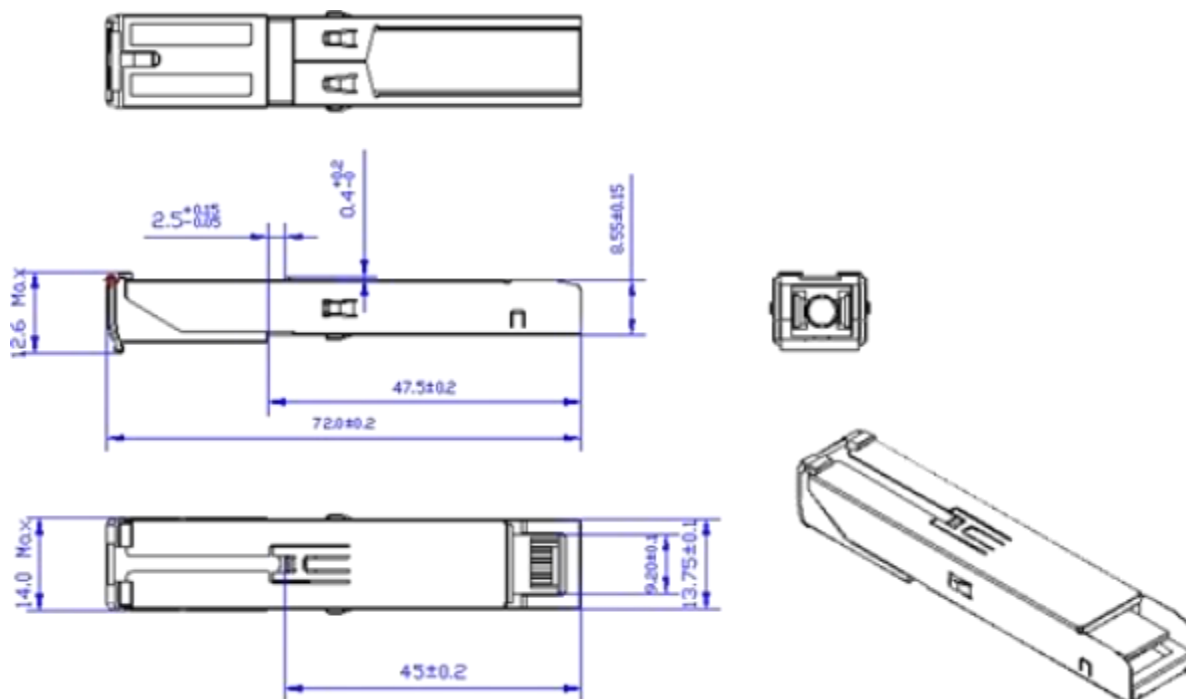

Recommended Host Board Power Supply Circuit

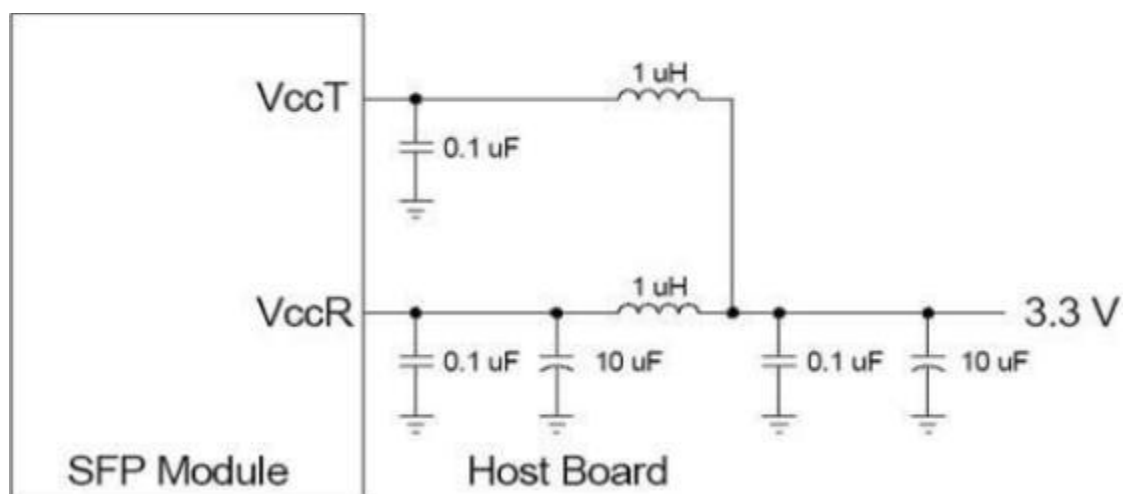

EPROM Information

EEPROM Diagram

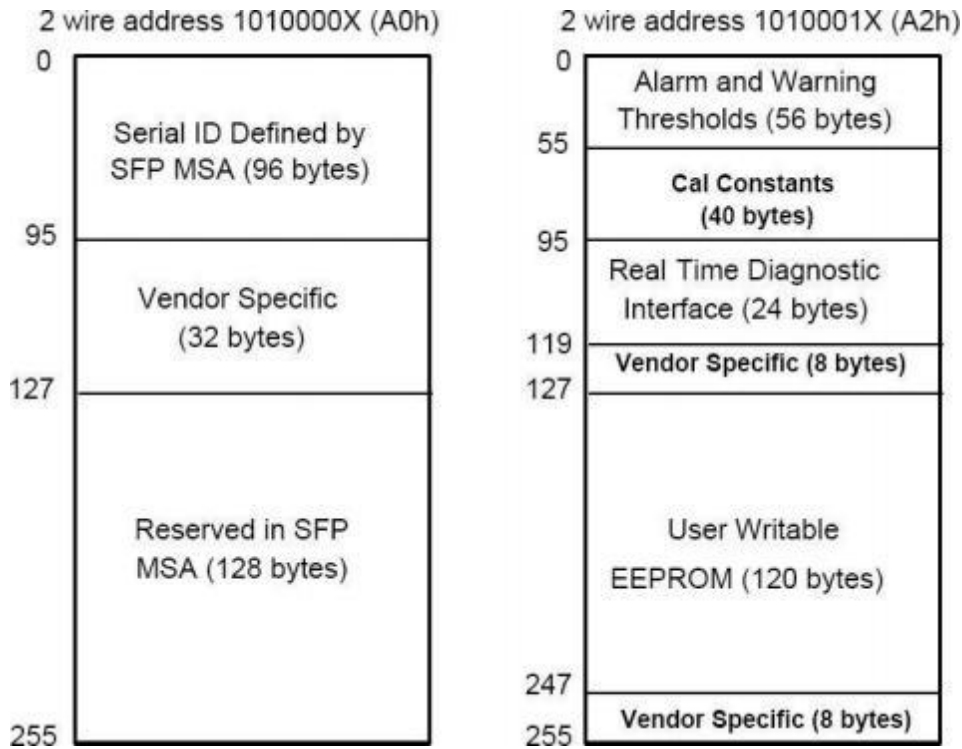

EEPROM Memory Content (A0h)

Addr.	Field Size (Bytes)	Name of Field	Hex	Description
0	1	Identifier	03	SFP transceiver
1	1	Ext. Identifier	04	MOD4
2	1	Connector	01	SC
3-10	8	Transceiver	00 00 00 00 00 00 00 00	
11	1	Encoding	03	NRZ
12	1	BR, Nominal	0C	1.244Gbps
13	1	Reserved	00	
14	1	Length (9um)-km	14	20(km)
15	1	Length (9um)	C8	200(100m)

16	1	Length (50um)	00	Not Support MMF
17	1	Length (62.5um)	00	Not Support MMF
18	1	Length (Copper)	00	Not Support Copper
19	1	Reserved	00	
20-35	16	Vendor name	53 4F 55 52 43 45 50 48 4F 54 4F 4E 49 43 53 20	"FS "(ASCII)
36	1	Reserved	00	
37-39	3	Vendor OUI	00 00 00	
40-55	16	Vendor PN	53 50 53 33 34 32 34 54 48 50 54/45 44 46 50 20 20	"GPON-ONU-34-20BI"(ASCII)
56-59	4	Vendor Rev	xx xx 20 20	ASCII("30 31 20 20" means 1.0 Revision)
60-61	2	Wavelength	05 1E	Tx wavelength:1310nm
62	1	Reserved	00	
63	1	CC_BASE	xx	Check sum of byte 0-62
64-65	2	Options	00 1A	64 = 0x00, reserved 65 = 0x1A, TX_DISABLE/ TX_FAULT/RX_LOS supported
66	1	BR, max	00	
67	1	BR, min	00	
68-83	16	Vendor SN	xx xx xx xx xx xx xx xx xx xx xx xx xx xx xx xx	ASCII
84-91	8	Date code	xx xx xx xx xx xx 20 20	Year(2 bytes),Month(2 bytes), Day(2 bytes)
92	1	Diagnostic Monitoring Type	68	Compliant with SFF-8472 V10.3 Internally Calibrated Received power measurement type -Average Power
93	1	93	F0	Diagnostics (Optional Alarm/warning flags) Soft TX_FAULT monitoring implemented. Soft RX_LOS monitoring implemented

94	1	SFF-8472 Compliance	05	Indicates the revision of SFF-8472 with which the transceiver complies. Value depends on module features.
95	1	CC_EXT	xx	Check sum of byte 64-94
96-255	64	Vendor Specific		

EEPROM Memory Content (A2h)

Addr.	Field Size (Bytes)	Name of Field	Hex	Description	
0	00	2	Temp High Alarm	5F 00	95°C
2	02	2	Temp Low Alarm	CE 00	-50°C
4	04	2	Temp High Warning	5A 00	90°C
6	06	2	Temp Low Warning	D3 00 FB 00	-45°C
8	08	2	Voltage High Alarm	8C A0	3.6V
10	0A	2	Voltage Low Alarm	75 30	3.0V
12	0C	2	Voltage High Warning	88 B8	3.5V
14	0E	2	Voltage Low 3.6VWarning	79 18	3.1V
16	10	2	Bias High Alarm	AF C8	90mA
18	12	2	Bias Low Alarm	00 00	0mA
20	14	2	Bias High Warning	88 B8	70mA
22	16	2	Bias Low Warning	00 00	0mA
24	18	2	TX Power High Alarm	F6 77	8dBm
26	1A	2	TX Power Low Alarm	15 F7	-2.5dBm
28	1C	2	TX Power High Warning	C3 C6	7dBm
30	1E	2	TX Power Low Warning	1B A7	-1.5dBm
32	20	2	RX Power High Alarm	0C 5A	-5dBm
34	22	2	RX Power Low Alarm	00 08	-31dBm
36	24	2	RX Power High Warning	09 CF	-6dBm
38	26	2	RX Power Low Warning	00 0A	-30dBm

40-45	28-2D	6	MAC address	xx xx xx xx xx xx	MAC Address
46-55	2E-37	10	Reserved	00...000	Reserved
56	38	4	RX_PWR(4) Calibration	00 00 00 00	4th order RSSI calibration coefficient
60	3C	4	RX_PWR(3) Calibration	00 00 00 00	3rd order RSSI calibration coefficient
64	40	4	RX_PWR(2) Calibration	00 00 00 00	2nd order RSSI calibration coefficient
68	44	4	RX_PWR(1) Calibration	3F 80 00 00	1st order RSSI calibration coefficient
72	48	4	RX_PWR(0) Calibration	00 00 00 00	0th order RSSI calibration coefficient
76	4C	2	TX_I(Slope) Calibration	01 00	Slope for Bias calibration
78	4E	2	TX_I(Offset) Calibration	00 00	Offset for Bias calibration
80	50	2	TX_PWR(Slope) Calibration	01 00	Slope for TX Power calibration
82	52	2	TX_PWR(Offset) Calibration	00 00	Offset for TX Power calibration
84	54	2	T(Slope) Calibration	01 00	Slope for Temperature calibration
86	56	2	T(Offset) Calibration	00 00	Offset for Temperature calibration, in units of 256ths C
88	58	2	V(Slope) Calibration	01 00	Slope for VCC calibration
90	5A	2	V(Offset) Calibration	00 00	Offset for VCC calibration
92	5C	3	Reserved	00 00 00	Reserved
95	5F	1	Checksum	xx	Checksum

Digital Diagnostic Specification (A2h)

Data Address	Parameter	Range	Accuracy
96-97	Temperature	-40 to 85/0~85 °C	± 5 °C
98-99	Vcc Voltage	0 to Vcc	± 5%
100-101	Bias Current	0 to 100mA(Note)	± 10%
102-103	TX Power	0.5 to 5dBm	± 3 dB
104-105	RX Power	-28 to -8dBm	± 3 dB

Note: Only for continuous mode

Order Information

Part Number	Description
GPON-SFP-ONT-MAC-I	GPON Stick SFP ONU 1310nm/ 1490nm 1.25GTx/2.5GRx Class B+ 20km Industrial DDM LC SMF Module
GPON-SFP-ONT-MAC-I	GPON Stick SFP ONU 1310nm/ 1490nm 1.25GTx/2.5GRx Class B+ Web GUI 20km Industrial DDM SC SMF Module
GPON-SFP-OLT-MAC-I	GPON Stick SFP OLT 1490nm/ 1310nm 2.5GTx/1.25GRx Class C+ 20km Industrial DDM SC SMF Module